

## Crochets de toiture pour SingleRail

Type / illustration	Matériel	Largeur plaque de base [L]	Hauteur sous bras [H <sub>1</sub> ] Hauteur du bras [H <sub>2</sub> ] Hauteur totale [H <sub>3</sub> ]	Profondeur [P]	Numéro d'article
<b>CrossHook 3S Set</b> 	Aluminium	100 mm	<ul style="list-style-type: none"> <li>40/47/54 mm</li> <li>56 mm</li> <li>Env. 123/130/137 mm</li> </ul>	83 mm	2001672
<b>CrossHook 4S Set</b> 	Aluminium	100 mm	<ul style="list-style-type: none"> <li>40/47/54 mm</li> <li>55 - 85 mm</li> <li>120,5 - 165 mm</li> </ul>	83 mm	2001821
<b>SingleHook 1.1*</b> 	Aluminium	100 mm	<ul style="list-style-type: none"> <li>47,1 mm</li> <li>56 mm</li> <li>162,9 mm</li> </ul>	83 mm	2001928
<b>SingleHook Alpin</b> 	Aluminium	100 mm	<ul style="list-style-type: none"> <li>35 mm</li> <li>60 mm</li> <li>169 mm</li> </ul>	110 mm	2003155
<b>CrossBoard</b> pour CrossHook 3S/4S et <b>SingleBoard</b> pour SingleHook 1.1 	Aluminium	2100 mm	Voir CrossHook 3S/4S ou SingleHook 1.1!		2001972 / 2002935
<b>CrossHook 2 (BS EN 490)</b> 	Aluminium	150 mm	<ul style="list-style-type: none"> <li>44 mm</li> <li>46 mm</li> <li>100 mm</li> </ul>	116 mm	2003175
<b>SingleHook Vario*</b> 	Edelstahl	100 mm	<ul style="list-style-type: none"> <li>45 - 65 mm</li> <li>68 mm</li> <li>172 - 192 mm</li> </ul>	110 mm	2002651

### Schéma CrossHook

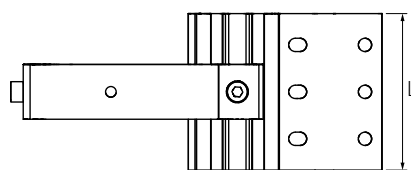
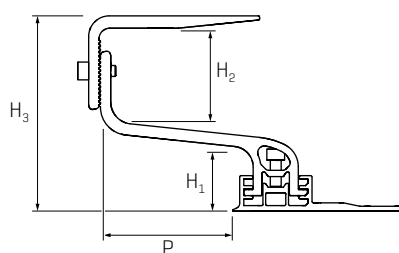

### Schéma SingleHook

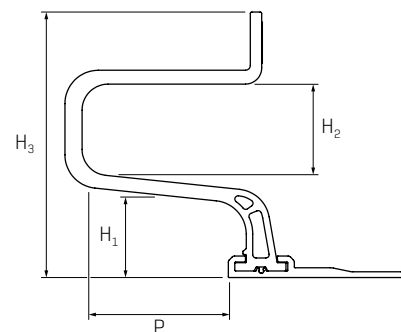

\* Convient uniquement pour SingleRail.

## Crochets de toiture pour SolidRail

Type / illustration	Plaque de base [a x b x c]	Bras [d x e]	Bras [H <sub>1</sub> ]/[H <sub>2</sub> ]	Hauteur totale env. [H <sub>3</sub> ]	Profondeur [P]	Numéro d'article
<b>CrossHook 4SL</b> * <sup>1</sup> 	100 x 124 x 3,5 - 6,0 mm	35 x 8,7 mm	40/47/54 / 55 - 85 mm	120,5 - 165 mm	83 mm	2003156
<b>CrossHook 3S+/4+</b> * <sup>1</sup> 	100 x 124 x 3,5 - 6,0 mm	35 x 8,5 mm	<ul style="list-style-type: none"> <li>▪ 3S+: 40/47/54 mm / 56 mm</li> <li>▪ 4S+: 40/47/54 mm / 55 - 85 mm</li> </ul>	<ul style="list-style-type: none"> <li>▪ 3S+: Ca. 123/ 130/137 mm</li> <li>▪ 4S+: 120,5 - 165 mm</li> </ul>	83 mm	2002390 / 2002402
<b>Tuiles flamandes</b> * <sup>2</sup> 	150 x 60 x 5 mm	30 x 6 mm	47/65 mm	134 mm	98 mm	1000001
	180 x 80 x 4 mm	35 x 6 mm	38/69 mm	124 mm	91 mm	1000096
	180 x 80 x 4 mm	35 x 6 mm	47/68 mm	138 mm	127 mm	1001508
	180 x 80 x 5 mm	40 x 8 mm	47/55 mm	121 mm	87 mm	1000764
<b>Vario 1</b> * <sup>2</sup> 	150 x 60 x 5 mm	30 x 6 mm	43 / 41 - 71 mm	112 - 145 mm	95 mm	1000125
<b>Vario 2</b> * <sup>2</sup> 	140 x 55 x 5 mm	30 x 6 mm	49 - 58 / 57 - 76 mm	128 - 156 mm	94 mm	1000107
<b>Couverture de toit double en tuiles plates écailles</b> * <sup>3</sup> 	75 x 52 x 4 mm	75 x 4 mm	34/62 mm	119 mm	234 mm	2003073
<b>Couverture de toit en ardoise</b> * <sup>2</sup> 	40 x 250 mm	40 x 65 mm	-/60 mm	72 mm	72 mm	1000373
<b>Coppo</b> * <sup>2</sup> 	150 x 60 x 5 mm	30 x 5 mm	18 / 88 - 118 mm	123 - 153 mm	120 mm	1001068

\*<sup>1</sup> Matériel: Aluminium · \*<sup>2</sup> Matériel: Acier inoxydable · \*<sup>3</sup> Matériel: Magnelis 1.0242 [S250GD+ZM310]

### Schéma

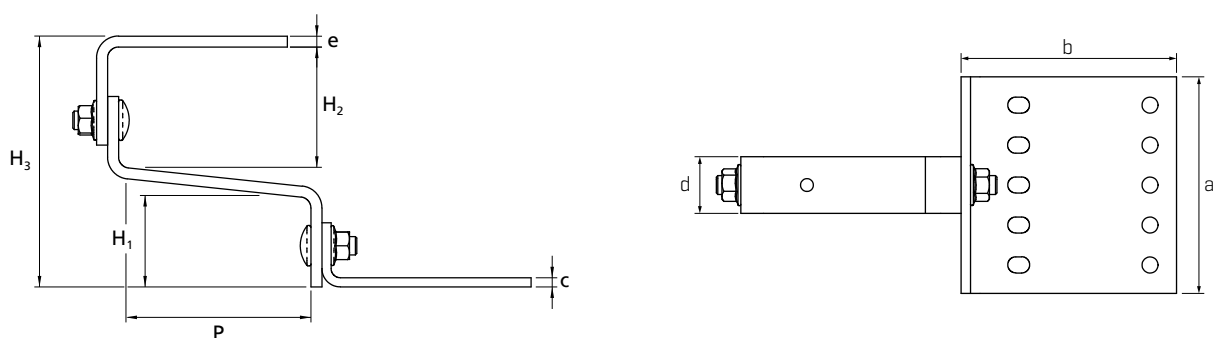



# Aperçu des fixations sur toiture

## Vis à double filetage

### Pour pannes bois

Fixation des rails SolidRail et CrossRail K2 dans les pannes bois sur toit en fibrociment ou tôles ondulées et trapézoïdales. Filetage métrique très long pour le réglage de la hauteur du système. Système prémonté avec tôle d'adaptation.

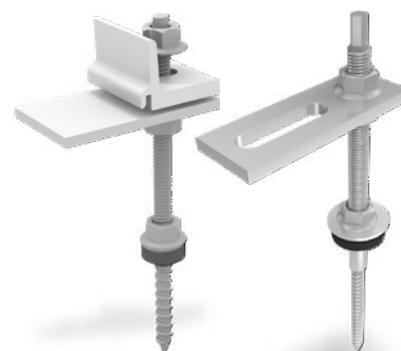

### Vis à double filetage SingleRail

Type	Numéro d'article
M10×180, hexagonal SW 7 mm	2003272
M10×200, hexagonal SW 7 mm	2003273
M10×250, hexagonal SW 7 mm	2003274
M12×200, hexagonal SW 9 mm	2003275
M12×250, hexagonal SW 9 mm	2003276
M12×300, hexagonal SW 9 mm	2003277

### Vis à double filetage SolidRail

Type	Numéro d'article
M10×180, hexagonal SW 7 mm	2000120
M10×200, hexagonal SW 7 mm	2000121
M10×250, hexagonal SW 7 mm	2000122
M12×200, hexagonal SW 9 mm	2000123
M12×250, hexagonal SW 9 mm	2000124
M12×300, hexagonal SW 9 mm	2000125

## Vis de fixation panneaux solaires

### Pour pannes acier, bois ou béton

Système vis de fixation pour panneaux solaires [acier inoxydable]. Pour fixation des SolidRail ou SingleRail dans les pannes sur toit en tôle trapézoïdale, fibrociment ou tôle ondulée. Plaques d'adaptation M10/M12 disponibles en option.



**Acier:** Fixation pour équipement solaire Ø 8,0 avec filetage M10×50, calotte E16

Type	Numéro d'article
8×85 / 50, longueur 135 mm	2003018
8×115 / 50, longueur 165 mm	2003019
8×155 / 50, longueur 205 mm	2003020
8×195 / 50, longueur 245 mm	2003021

**Acier:** Fixation pour équipement solaire Ø 8,0 avec filetage M10×50, FZD

Type	Numéro d'article
8×85 / 50, longueur 135 mm	2003013
8×115 / 50, longueur 165 mm	2003012
8×155 / 50, longueur 205 mm	2003016
8×195 / 50, longueur 245 mm	2003017

**Bois:** Fixation pour équipement solaire Ø 8,0 mm avec M10×50/70 mm, Filetage métrique E14 calotte ou EPDM joint FZD. Sur demande!



# Pinces à joint debout et systèmes de couverture



Type / illustration	Type de joint debout / système de couverture	Dimension d'ouverture [mm]	Rail de montage	Matériel	Numéro d'article
<b>Single Standing SeamClamp CF:x</b> 	Joint debout double 	7,0	SingleRail	Aluminium	2003024
<b>Single Round SeamClamp CF:x</b> 	Joint arrondi 	25,0	SingleRail	Aluminium	2002859
<b>Single Snap SeamClamp CF:x</b> 	Joint angulaire / snaplock 	14,0	SingleRail	Aluminium	2003083
<b>S-5! E-Mini-FL Standing SeamClamp</b> 	Joint debout double 	7,0	SolidRail	Aluminium	1001052
<b>S-5! Z-Mini-FL Round SeamClamp</b> 	Joint arrondi 	22,0	SolidRail	Aluminium	1000888
<b>Solid Snap SeamClamp CF:x</b> 	Joint angulaire / snaplock 	14,0	SolidRail	Aluminium	2003082
<b>Solid Standing SeamClamp</b> 	Joint debout double 	3,5	SolidRail	Acier inoxydable	2001712
<b>Solid Round SeamClamp</b> 	Toits Kalzip avec joint arrondi 	10,5	SolidRail	Acier inoxydable	2001853
<b>Rib-Roof Evolution Clamp</b> 	Rib-Roof Evolution 	23,0	SolidRail	Aluminium	2002226
<b>Rib-Roof Speed 500 Clamp</b> 	Rib-Roof Speed 500 	17,0	SolidRail	Aluminium	2002225
<b>Rib-Roof 465 Clamp</b> 	Rib-Roof 465 profil trapézoïdal 	12,0	SolidRail	Aluminium	2002118
<b>RibClamp KL</b> 	Klip-Lok classic 700 Klip-Lok 406 Klip-Tite 700 	20,0	SolidRail ou MiniClamp sans rail de base	Aluminium	2002857